



LTE eNB Scheduler performance experiments



3rd Fed4FIRE Engineering Conference

14.03.2018

Agenda



1. LTE eNB Scheduler overview
2. Fed4FIRE+ OC1 Experiment



LTE eNB Scheduler

OVERVIEW

LTE eNB Scheduler

- Implemented based on extended Small Cell Forum recommendation
- Support for Carrier Aggregation
- Ability to guarantee GBR traffic
- Real-life imperfection corrections – wrong CQI reporting compensation
- 30% higher peak throughput with maintaining edge cell users performance

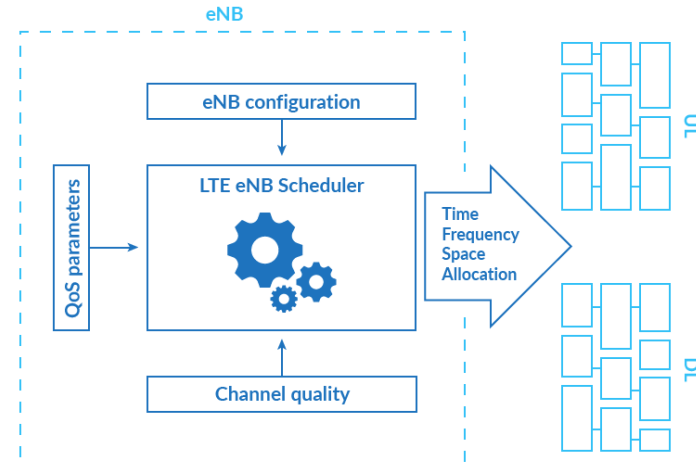
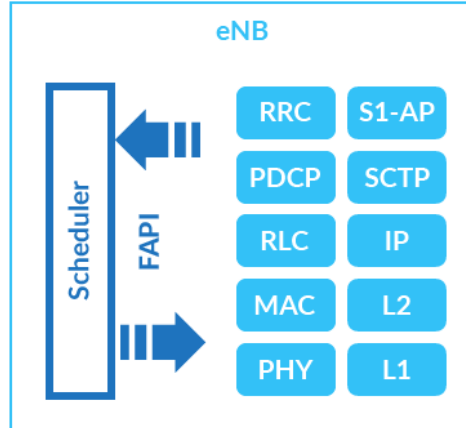

LTE eNB Scheduler



Algorithm/ Component	Round Robin	maxCQI	Proportional Fair	M-LWDF	M-QBER	LTE eNB Scheduler
Channel conditions	No	Yes	Yes	Yes	Yes	Yes
Historical throughput	No	No	Yes	Yes	Yes	Yes
Packet delay	No	No	No	Yes	No	Yes
Queue length	No	No	No	No	Yes	Yes
GBR/non-GBR traffic	No	No	No	No	No	Yes
Carrier Aggregation*	No	No	No	No	No	Yes
Wrong CQI correction	No	No	No	No	No	Yes

LTE eNB Scheduler

AS A PART OF SOFTWARE-DEFINED RAN

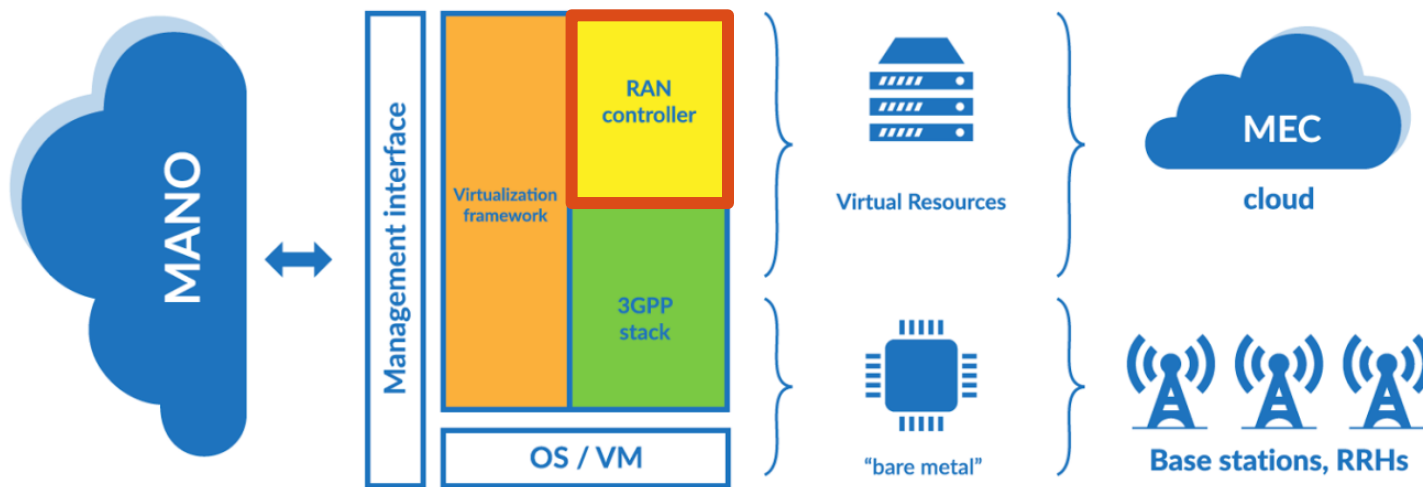

LTE eNB Scheduler

AS A PART OF SOFTWARE-DEFINED RAN

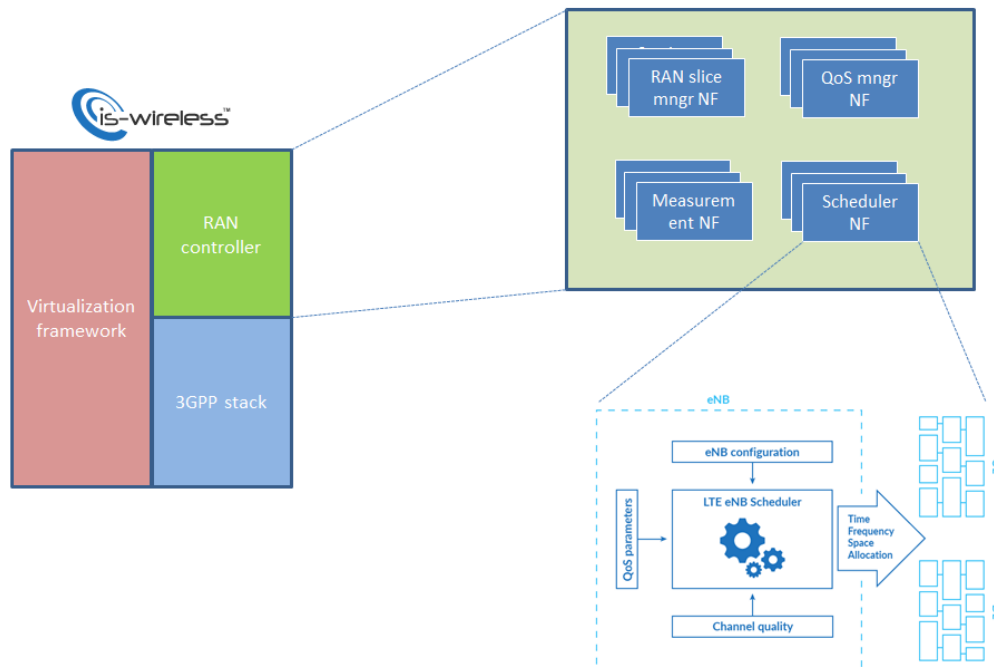

Fed4FIRE+ OC1 Experiment

LTE eNB Scheduler performance experiments



GOALS

- LTE eNB Scheduler experiments in the environment composed of LTE base station and multiple, simultaneously connected UE nodes
- KPI measurement (such as throughput, packet delay, packet loss, etc) in various environment conditions
- LTE eNB Scheduler testing using open-source software for LTE eNB/UE protocol stacks and various SDR front-end devices

LTE eNB Scheduler performance experiments



CHALLENGES

- Deployment of LTE eNB Scheduler in cooperation with open-source LTE protocol stack – OpenAirInterface (OAI) – and expressMIMO2 platform
- LTE eNB Scheduler and OAI support for COTS UE and UE open-source protocol stack
- KPI measurements for Carrier Aggregation transmission

LTE eNB Scheduler performance experiments

EXPERIMENT SETUP

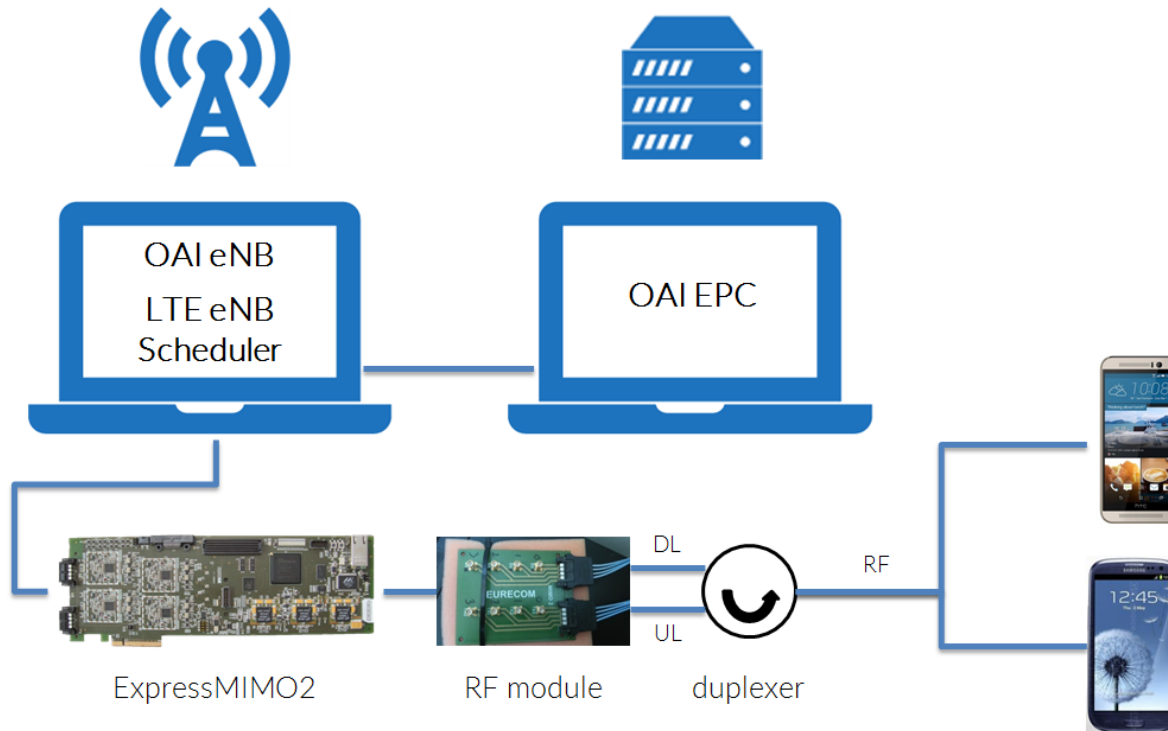

LTE eNB Scheduler performance experiments



SW/HW COMPONENTS

- OAI eNB - the branch supporting FAPI interface and CA functionality (feature-31-ff-scheduler-api)
- OAI EPC – master branch at the newest release
- LTE eNB Scheduler - basic and advanced algorithms
- expressMIMO2 + RF module
- 4x COTS UE with test SIM cards
- 2x LTE duplexer, band 7
- USRP B210 for spectrum analysis
- Tools: TesteDroid and aLTERNative (new ISW's product supporting LTE open-source protocol stack)



Samsung S3



S4



S6



HTC One M9

LTE eNB Scheduler performance experiments

TECHNICAL RESULTS

- Successful deployment of LTE eNB Scheduler in cooperation with OAI and expressMIMO2

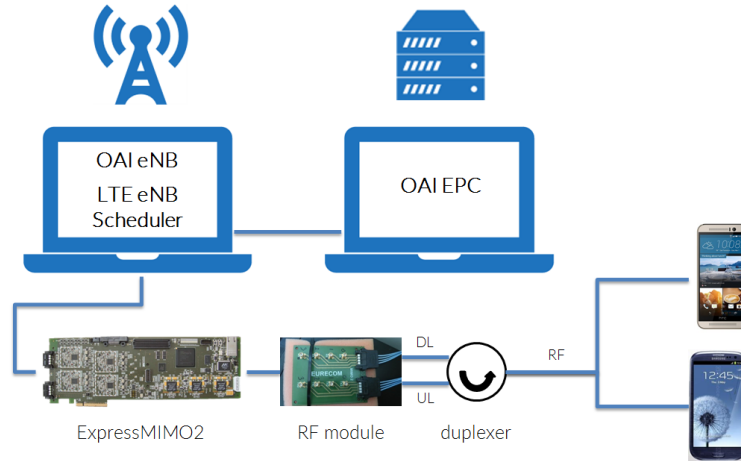

- Carrier Aggregation transmission:
 - 2x CC, band 7, 2x 25 RB
- LTE eNB Scheduler – advanced algorithm
- PC nodes:
 - i7 CPU, 4 cores, 3.4 GHz
 - EPC: Ubuntu 16.04, 64-bit
 - eNB: Ubuntu 14.04, 64-bit, 3.19.0-61-lowlatency

LTE eNB Scheduler performance experiments

TECHNICAL RESULTS

- The range of RF front-end equipment that is compatible with deployed LTE eNB successfully verified

The experiment showed that OAI (feature-31-ff-scheduler-api) does not support single carrier transmission

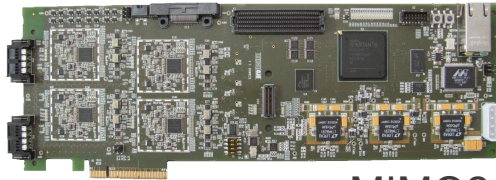

expressMIMO2

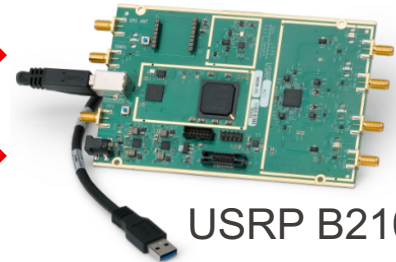

USRP B210

LTE eNB Scheduler performance experiments



TECHNICAL ISSUES

- OAI and ExpressMIMO2 communication fails due to insufficient PC performance
 - only one PC that could achieve the performance allowing to cooperate with ExpressMIMO2 without errors from OAI nor RF front-end side
 - received errors for “missed slots” and “hardware stopped”

LTE eNB Scheduler performance experiments



TECHNICAL ISSUES

- The LTE Random Access procedure between LTE base station and provided COTS UEs could not be completed
 - Some of the provided smartphones could not cooperate with the deployed base station.
 - RA procedure could not be completed due to the MCC/MNC configuration issue for SIM cards

LTE eNB Scheduler performance experiments



TECHNICAL ISSUES

- The incomplete control of the environment influenced the experiment reliability, i.e.:
 - Irregular transmissions from commercial base stations at the tested spectrum band
 - ExpressMIMO2 sends the unidentified RF signals
 - The reduced control on the UE behaviour
 - The COTS UE dedicated to the experiment were not always available (e.g. due to uncharged battery).

LTE eNB Scheduler performance experiments



ADDITIONAL TECHNICAL OUTCOMES

- Additional implementation for LTE eNB Scheduler
 - to increase the efficiency in cooperation with OAI
 - required for bug fixing
- New ideas for better OAI support within aLTErnative (some already implemented):
 - improvements of the eNB and EPC configuration procedures,
 - better support for software compilation parameters,
 - support for the FAPI compilation, which is necessary for LTE eNB Scheduler application.

LTE eNB Scheduler performance experiments



CONCLUSIONS

1. LTE eNB (OAI + LTE eNB Scheduler) works stable, however the KPI measurements could not be performed due to many encountered issues.
2. LTE eNB is not yet resistant to the environment conditions - it might be a good idea to repeat the experiment in more controllable environment (using e.g. cables, Faraday cage)
3. The high PC performance (incl. features for power management, CPU freq scaling and hyperthreading) is required to support expressMIMO2
4. OAI software require additional implementation
 1. for EPC part in order to fully support LTE attach procedure
 2. for eNB part (at feature-31-ff-scheduler-api) in order to support single carrier transmission and all provided COTS UE



Co-funded by the
European Union



Co-funded by the
Swiss Confederation

This project has received funding from the European Union's Horizon 2020 research and innovation programme, which is co-funded by the European Commission and the Swiss State Secretariat for Education, Research and Innovation, under grant agreement No 732638.

**THANK YOU FOR
YOUR ATTENTION**

WWW.FED4FIRE.EU